



SolarShower 600 Manual

This instruction contains important information for using the product for the first time. Please keep this instruction for later reference. They should always accompany the product in the Event of transfer a new user.

1 OVERVIEW

- 1.1 The solar pump is designed for fountain, pond or outdoor use. In order for the solar pump to operate, the solar panel needs to be in direct sunlight.
- 1.2 This solar pump is equipped with battery pack and can be switched on and off by a touch switch on the control housing. In evening, four built-in white LEDs will give light automatically to enhance the beauty scene of the water jet.

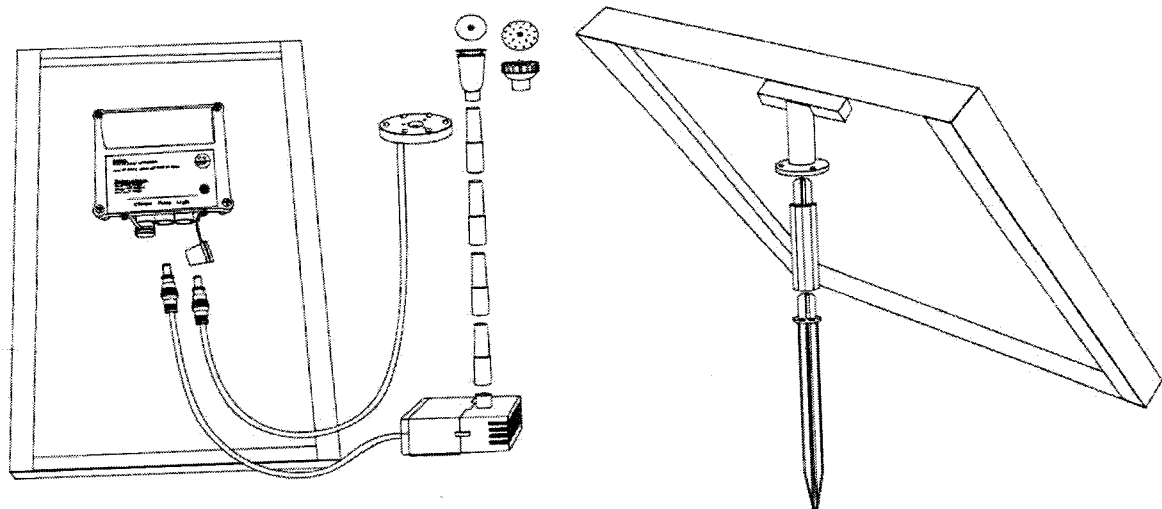

2 ASSEMBLING AND USING YOUR PRODUCT

- 2.1 Unpack all components carefully.
- 2.2 Place the pump underwater and make sure that, it is fully immersed in water. In case the pump tube is too far from the surface of water, you can raise the pump by using stones or brick underlay.
- 2.3 Connect fountain heads and LED light as required;
- 2.4 Adjust the water jet as needed
- 2.5 Connect the pump cable to the socket of the control housing on the rear side of the solar panel;
- 2.6 Connect the LED light (optional) cable to the socket of the control housing;
- 2.7 The solar pump is now ready to use.

3 CAUTION

- 3.1 Do not strike the solar panel
- 3.2 Do not let the pump run dry for long time
- 3.3 Do not lift the pump by the power cord
- 3.4 Operate in freshwater only